

ELEVATIONS:

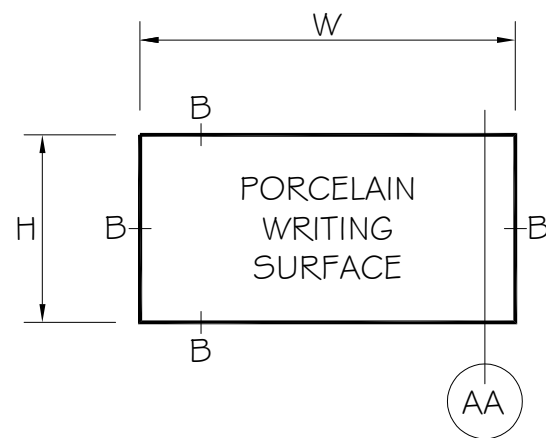

SECTION AA

MARKERBOARD
OPTION 01

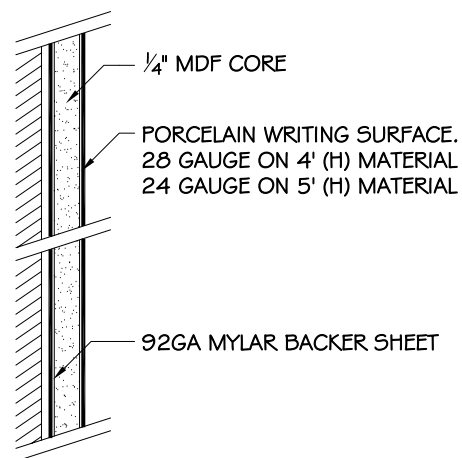

OPTIONAL COLORS:

- 29 WHITE HIGH GLOSS
- 29L WHITE LOW GLOSS

TOP & BOTTOM TRIM DETAIL

REGULAR TRIM "B":

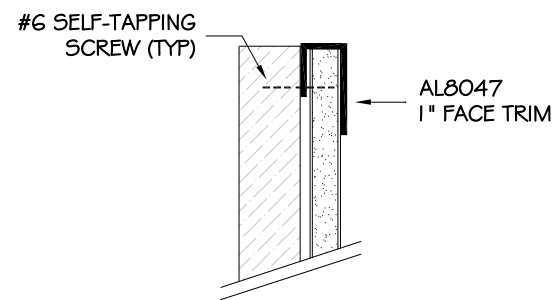

REGULAR TRIM "B":

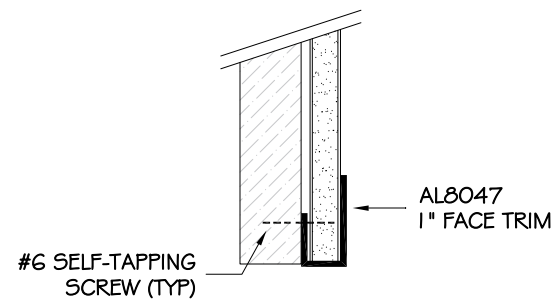

DETAIL

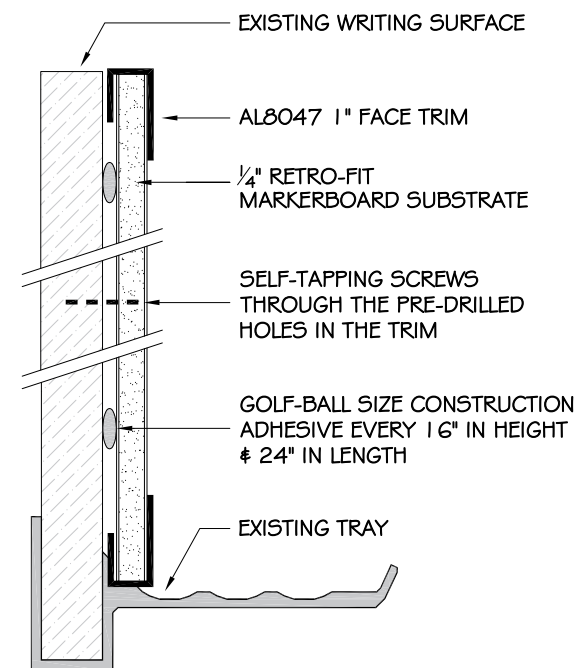

ALUMINUM TRIM:

SERIES 9200 "RETRO FIT"
FINISH: ***
FACE TRIM: 1"

DESCRIPTION:

9200 SERIES "PRE-FRAMED"
- 01 - WHITEBOARDS

PRODUCT CODE:

92	0X	XX	YXX	XXX
SERIES	BOARD	TRIM	SIZE	COLOR

MOUNTING METHOD:

- SELF - TAPPING SCREW (TYP)

NOTES AND/OR APPROVAL



2301 East High Avenue, New Philadelphia
OHIO 44663
Phone: (330) 308-8667
www.asi-visualdisplayproducts.com

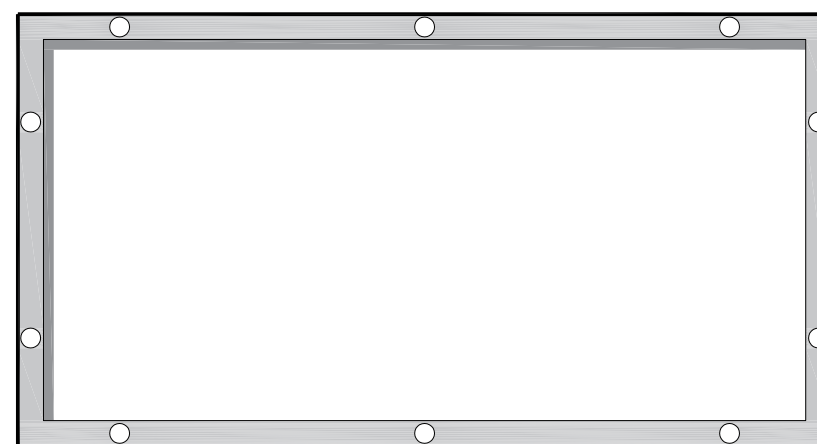

0.1285" DIA HOLES

F:\ACADR\14\FILENAME
TDS SERIES 9200 PRE-FRAMED

PAGE NO.
1 OF 1

DRAWN BY:
U. HERNANDEZ

DATE:
15 APRIL 2025